

# CES6-CT6

---

## CES6-CT6

Low-Power High-Performance Low-Cost 48 Channel SMD GPS Module :

### Features

- ◆ 48 track verification channels
- ◆ SBAS(WASS or EGNOS)
- ◆ Tracking sensitivity -163dBm
- ◆ Active Jammer Remover
- ◆ Extremely fast TTFF at low signal level
- ◆ Multipath detection and suppression
- ◆ Accuracy 2.5m CEP
- ◆ Tracking current ~35mA
- ◆ Supports active and passive antenna
- ◆ Operating temperature -40 ~ +85°C
- ◆ RoHS compliant

### Applications

- ◆ Personal positioning
- ◆ Navigation
- ◆ Smart Phone
- ◆ Automatic Vehicle Location

### Product Description

The CES6-CT6 is a small form factor GPS module solution intended for a broad range of Original Equipment Manufacturer (OEM) products, where fast and easy system integration and minimal development risk is required. The user only need to provide DC power of 3.0V ~ 3.6V and GPS signal; the CES-CT6 will output navigation solution in standard NMEA-0183.

## Receiver Specification

### ◆ Electrical Spceification

Parameter	Min	Typ	Max	Unit
Power Supply (VDD)	3.0	3.3	3.6	V
Backup battery voltage(VBAT)	2.0	3.3	3.6	V
Supply Current for not 3D fixed	45	50	55	mA
Supply Current for 3D fixed	35	38	45	mA
RF out power for ANT(VRF)	3.0	3.3	3.6	V

### ◆ DC Electrical characteristics

Paramter	Symbol	Min	Typ	Max	Units
High Level input Voltage	V <sub>IH</sub>	0.7*VCC		3.6	V
Low Level input Voltage	V <sub>IL</sub>	-0.4		0.45	V
High Level output Voltage	V <sub>OH</sub>	0.75*Vg <sub>cc</sub>		Vg <sub>cc</sub>	V
Low Level output Voltage	V <sub>OL</sub>			0.4	V
High Level output Current	I <sub>OH</sub>		2		mA
Low Level output Current	I <sub>OL</sub>		2		mA

Vg<sub>cc</sub> is 1.8V input .

### ◆ Receiver Description :

- Tracking Sensitivity -163dBm .
- Cold Star < 35s , with CGEE <15s .
- Warm Star < 35s , with CGEE <15s .
- Hot Star < 1s .
- Accuracy < 2.5m CEP .
- Operational Limits Altitude < 18,000m and velocity < 515m/s .
- Serial Interface 3.3V LVTTTL level .
- Protocol NMEA-0183 V3.01 .  
GPGGA, GPGLL, GPGSA, GPGSV, GPRMC, GPVTG\*9600 baud, 8, N, 1
- Datum : Default WGS-84 .

The CAN6-S features 48 channel GPS receiver with fast time to first fix and improved -148dBm cold start sensitivity. The superior cold start sensitivity allows it to acquire, track, and get position fix autonomously in difficult weak signal environment. The receiver's -163dBm tracking sensitivity allows continuous position coverage in nearly all application environments.

- Multi-path Mitigation : Advanced multi-path detection and suppression .

- Input Voltage : 3.3V DC +/-10% .
- Operating Temperature : -40oC ~ +85oC .
- Storage Temperature : -55 ~ +100oC .
- Humidity : 5% ~ 95% .
- Dimension :16mm L x 13mm W

## Product Dimensions

Dimensions : 13mmX16mmX2.6mm

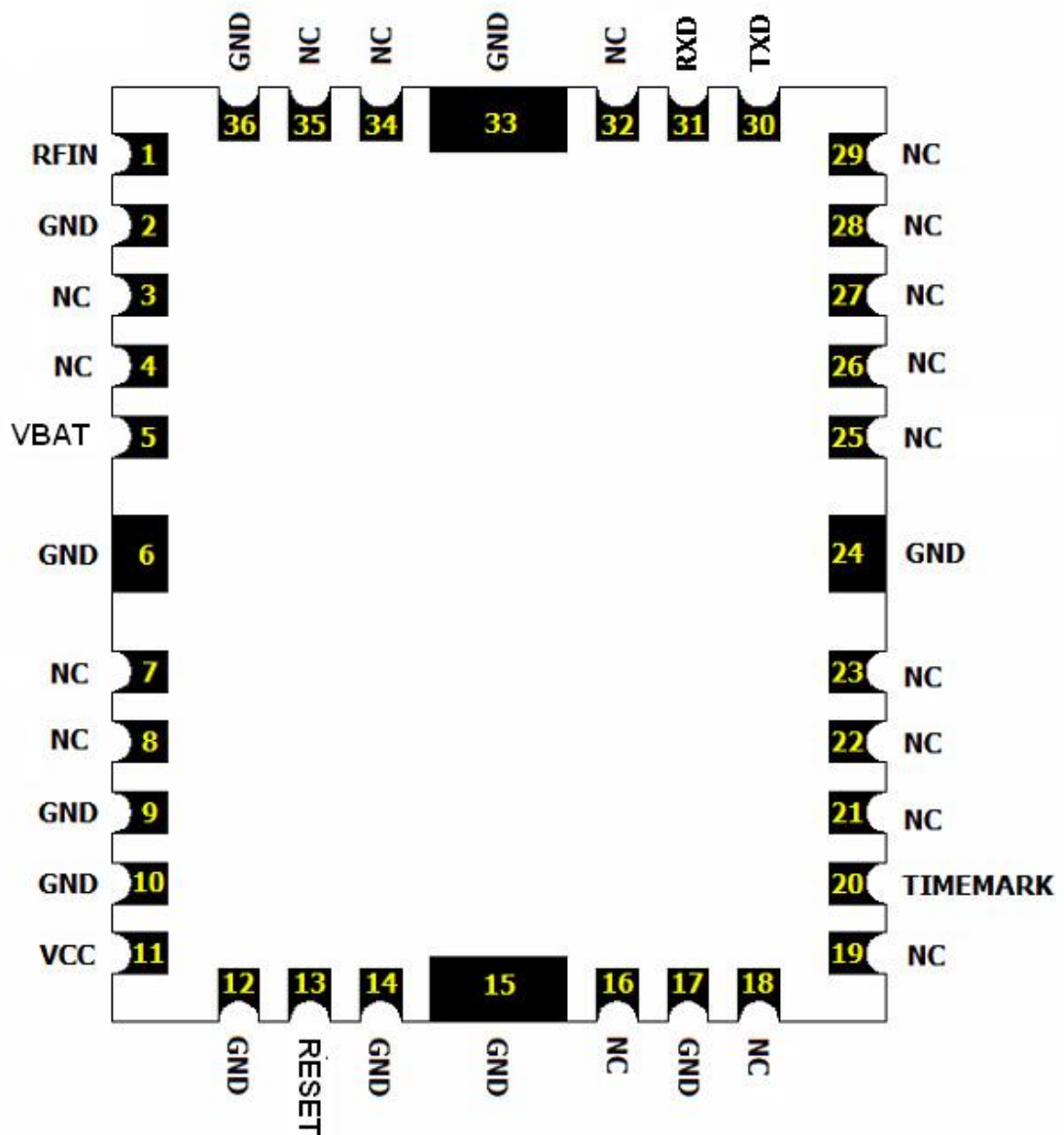

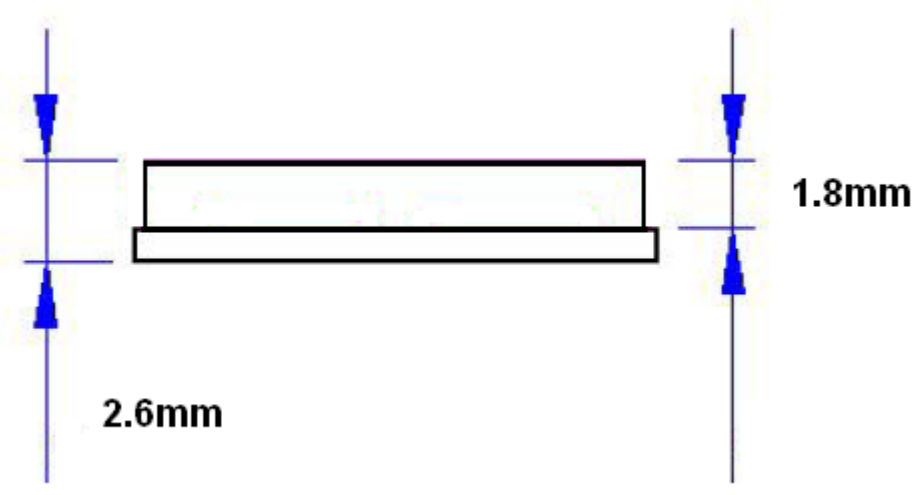
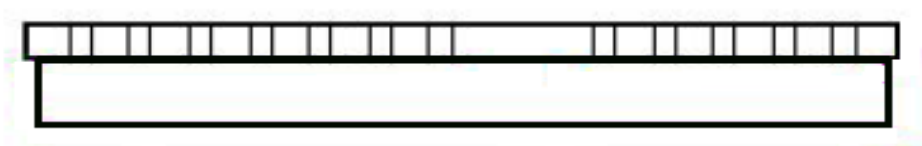

## Applicaation circuit :

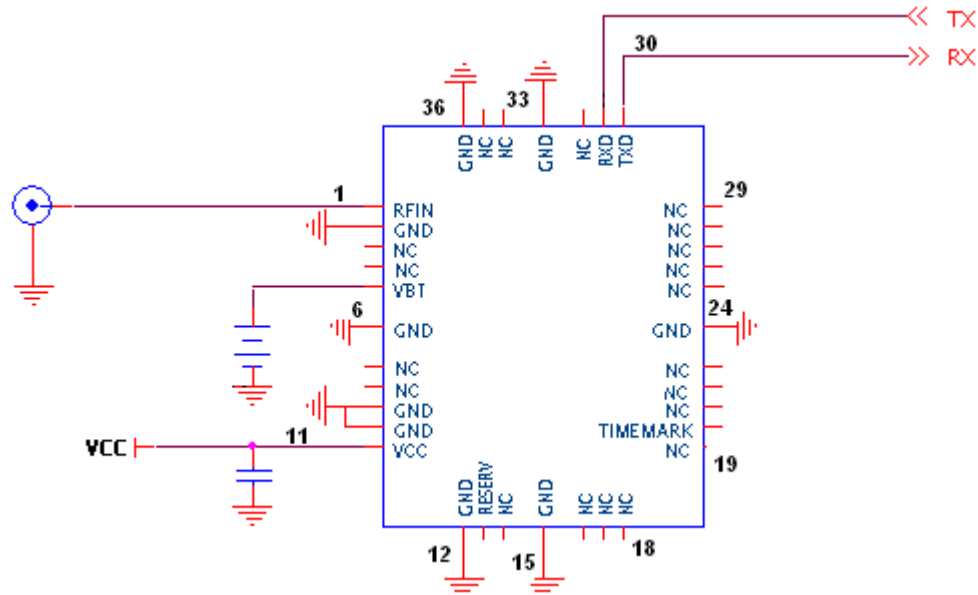

## GPS Ative antenna specification (option)

Frequency	1575.42MHz	GAIN	18~28dB
Output Impedance	50Ω	Noise Figure	2dB
Polarization	RHCP	Antenna Voltage	3V

## Pinout Description :

	Name	descripton
3,4,5,6,11,12,16 ,17,18,19,20	NC	No connection
13	1pps	One-pulse-per-second (1PPS) time mark output, 3V LVTTTL. The Pin provides one pulse-per-second output , when getting 3D position fix. The pulse duration is about 4msec at rate of 1 Hz.
7	Vout	3V output voltage from RF section Can supply 3V active antenna via an inductor-choke.If use Patch antenna not connect the pin.
8,10,21,22	RF_GND	RF_Ground
9	RF_IN	GPS RF input, connect to antenna
14	TXD	UART serial data output, 3V LVTTTL. One full-duplex asynchronous serial UART port is implemented. This UART output is normally

		used for sending position, time and velocity information from the receiver in NMEA-0183 format. When idle, this pin output HIGH.
15	RXD	UART serial data input, 3V LVTTTL. One full-duplex asynchronous serial UART port is implemented. This UART input is normally for sending commands or information to the receiver in binary protocol. In the idle condition, this pin should be driven HIGH. If the driving circuitry is powered independently of CAN6, ensure that this pin is not driven to HIGH when primary power to CAN6 is removed, or a 10K-ohm series resistor can be added to minimize leakage current from application to the powered off module.
1	V_BCKP	Backup supply voltage for internal RTC and backup SRAM, 1.8V ~ 6V. V_BCKP must be applied whenever VCC is applied. This pin should be powered continuously to minimize the startup time. If VCC and V_BCKP are both removed, the receiver will be in factory default mode upon power up, all user configuration set is lost. For applications the does not care cold starting every time, this pin can be connect to VCC.
2	VCC	Main power supply, 3.0V ~ 3.6V DC

Software Command :

## NMEA Output Command

GGA-Global Positioning system Fixed Data

\$GPGGA,hhmmss.sss,ddmm.mmmm,a,dddmm.mmmm,a,x,xx,x.x,x.x,M,,,,,xxxx\*hh<CR><LF>

Example:

\$GPGGA,111111.222,2222.0222,N,11111.5555,E,1,11,0.8,111.2,M,,,,,0000\*02<CR><LF>

Name	Example	Description
Message ID	\$GPGGA	GGA protocol header.
UTC Time	111111.222	hhmmss.sss.
Latitude	2222.0222	ddmm.mmmm.
N/S Indicator	N	Latitude hemisphere indicator, 'N' = North, 'S' = South.
Longitude	11111.5555	dddmm.mmmm.
E/W Indicator	E	Longitude hemisphere indicator, 'E' = East, 'W' = West.

GPS quality indicator	1	0 ---fix not available or invalid. 1---GPS SPA Mode, Fix valid. 2---Differential GPS, SPS Mode , Fix valid. 3---not supported
Satellites Used	11	Number of satellites in use, (00 ~ 12)
HDOP	0.8	Horizontal dilution of precision, (00.0 ~ 99.9)
Altitude	111.2	mean sea level (geoid), (-9999.9 ~ 17999.9)
DGPS Station ID	0000	Differential reference station ID, 0000 ~ 1023 NULL when DGPS not used.
Checksum	02	
<CR><LF>		End of message termination.

## ***GLL – Latitude/Longitude***

\$GPGLL,ddmm.mmmm,a,dddmm.mmmm,a,hhmmss.sss,A,a\*hh<CR><LF>

Example:

\$GPGLL,2222.2222,N,11111.5555,E,111111.333,A,A\*55<CR><LF>

Name	Example	Description
Message ID	\$GPGLL	Latitude and longitude of current position, time, and status.
Latitude	2222.2222	Latitude in ddmm.mmmm format Leading zeros transmitted
N/S Indicator	N	Latitude hemisphere indicator 'N' = North 'S' = South
Longitude	11111.5555	Longitude in dddmm.mmmm format Leading zeros transmitted
E/W Indicator	E	Longitude hemisphere indicator 'E' = East 'W' = West
UTC Time	111111.333	UTC time in hhmmss.sss format (000000.000 ~

		235959.999)
Status	A	Status, 'A' = Data valid, 'V' = Data not valid
Mode Indicator	A	Mode indicator 'N' = Data not valid 'A' = Autonomous mode 'D' = Differential mode 'E' = Estimated (dead reckoning) mode 'M' = Manual input mode 'S' = Simulator mode
Checksum	55	
<CR><LF>		End of message termination.

### ***GSA – GNSS DOP and Active Satellites***

\$GPGSA,A,x,xx,xx,xx,xx,xx,xx,xx,xx,xx,xx,x.x,x.x,x.x\*hh<CR><LF>

Example:

\$GPGSA,A,3,03,11,22,22,33,06,11,08,14,01,31,,1.2,0.8,0.9\*45<CR><LF>

Name	Example	Description
Mode	A	Mode 'M' = Manual, forced to operate in 2D or 3D mode 'A' = Automatic, allowed to automatically switch 2D/3D
Mode	3	Fix type 1 = Fix not available 2 = 2D 3 = 3D
Satellite used 1~12	03,11,22,22,33 ,06,11,08,14,0 1,31,,	Satellite ID number, 01 to 32, of satellite used in solution, up to 12 transmitted
PDOP	1.2	Position dilution of precision (00.0 to 99.9)
HDOP	0.8	Horizontal dilution of precision (00.0 to



		99.9)
VDOP	0.9	Vertical dilution of precision (00.0 to 99.9)
Checksum	45	Mode 'M' = Manual, forced to operate in 2D or 3D mode 'A' = Automatic, allowed to automatically switch 2D/3D
<CR><LF>		End of message termination.

## GSV – GNSS Satellites in View

\$GPGSV,x,x,xx,xx,xx,xxx,xx,...,xx,xx,xxx,xx

Example:

\$GPGSV,3,1,11,05,55,066,42,12,44,061,44,21,07,184,46,22,78,289,47\*70<CR><LF>

Name	Example	Description
Number of message	3	Total number of GSV messages to be transmitted (1-3)
Sequence number	1	Sequence number of current GSV message
Satellites in view	11	Total number of satellites in view (00 ~ 12)
Satellite ID	05	Satellite ID number, GPS: 01 ~ 32, SBAS: 33 ~ 64 (33 = PRN120)
Elevation	55	Satellite elevation in degrees, (00 ~ 90)
Azimuth	066	Satellite azimuth angle in degrees, (000 ~ 359 )

SNR	42	C/No in dB (00 ~ 99) Null when not tracking
Checksum	70	Total number of GSV messages to be transmitted (1-3)
<CR><LF>		End of message termination.

### ***RMC – Recommended Minimum Specific GNSS Dat***

\$GPRMC,hhmmss.sss,A,dddmm.mmmm,a,dddmm.mmmm,a,x.x,x.x,ddmmy,,a\*hh<CR><LF>

Example:

\$GPRMC,111111.111,A,2222.2222,N,11111.1111,E,000.0,000.0,030303,,,A\*51<CR><LF>

Name	Example	Description
UTC time	0111111.111	UTC time in hhmmss.sss format (000000.00 ~ 235959.999)
Status	A	Status 'V' = Navigation receiver warning 'A' = Data Valid
Latitude	2222.2222	Latitude in dddmm.mmmm format Leading zeros transmitted
N/S indicator	N	Latitude hemisphere indicator 'N' = North 'S' = South
Longitude	11111.1111	Longitude in dddmm.mmmm format Leading zeros transmitted
E/W Indicator	E	Longitude hemisphere indicator 'E' = East 'W' = West
Speed over ground	000.0	Speed over ground in knots (000.0 ~ 999.9)
Course over ground	000.0	Course over ground in degrees (000.0 ~ 359.9)
UTC Date	030303	UTC date of position fix, ddmmyy format
Mode indicator	A	Mode indicator 'N' = Data not valid 'A' = Autonomous mode 'D' = Differential mode 'E' = Estimated (dead reckoning) mode 'M' = Manual input mode 'S' = Simulator mode
checksum	51	

<CR><LF>		End of message termination.
----------	--	-----------------------------

## VTG – Course Over Ground and Ground Speed

GPVTG,x.x,T,,M,x.x,N,x.x,K,a\*hh<CR><LF>

Example:

\$GPVTG, 000.0,T,,M,000.0,N,0000.0,K,A\*3D<CR><LF>

Name	Example	Description
Course	000.0	True course over ground in degrees (000.0 ~ 359.9)
Speed	000.0	Speed over ground in knots (000.0 ~ 999.9)
Speed	0000.0	Speed over ground in kilometers per hour (0000.0 ~ 1800.0)
Mode	A	Mode indicator 'N' = not valid 'A' = Autonomous mode 'D' = Differential mode 'E' = Estimated (dead reckoning) mode 'M' = Manual input mode 'S' = Simulator mode
Checksum	3D	
<CR><LF>		End of message termination.

## PCB Layout

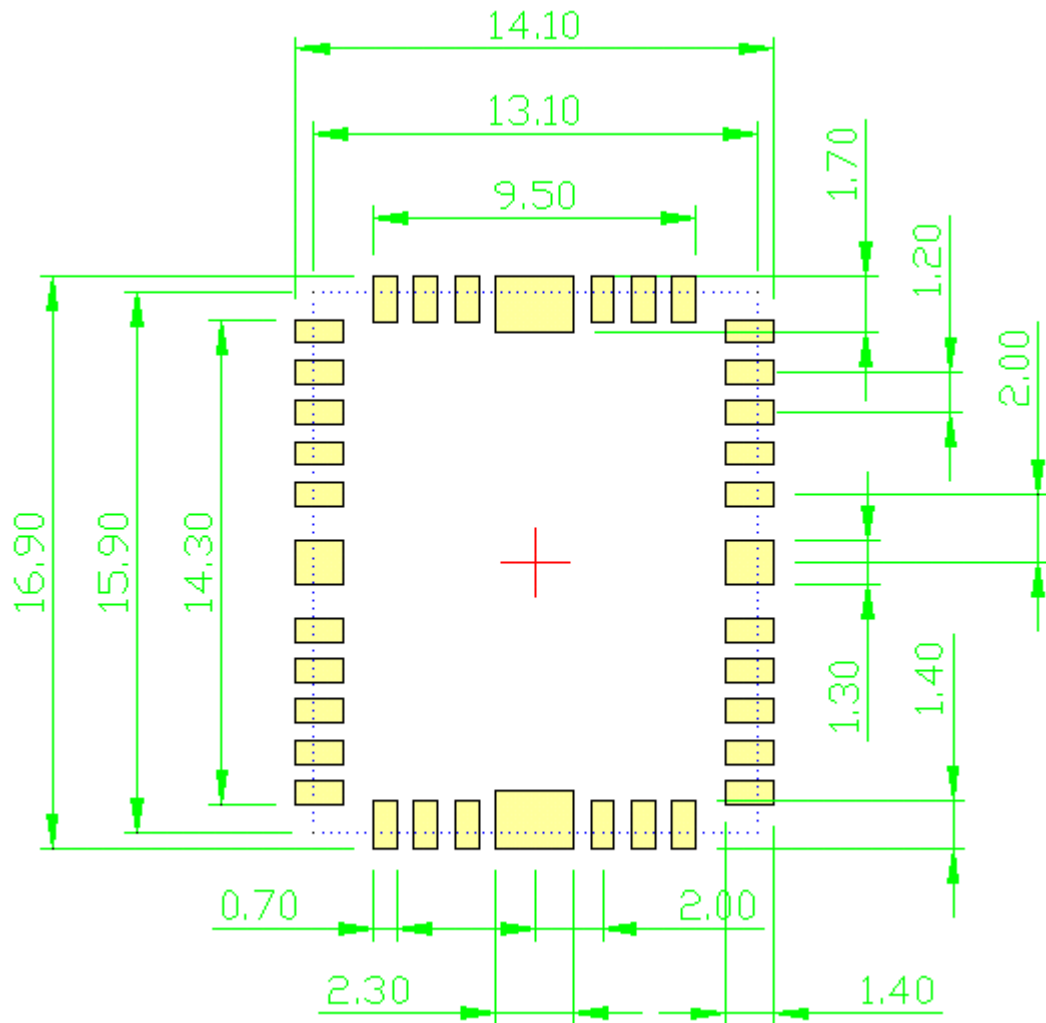

**RF:**The signal path from antenna to RF input of CAN6-S is the most critical part of application design. The goal is to provide optimal 50-ohm match between a 50-ohm antenna and the module 50-ohm RF input for maximum power transfer. The 50-ohm grounded coplanar wave guide, consisting of the RF input signal with RF ground on either sides and a RF ground underneath, is a good choice for efficiency.

**SMT Reflow  
Profile :**

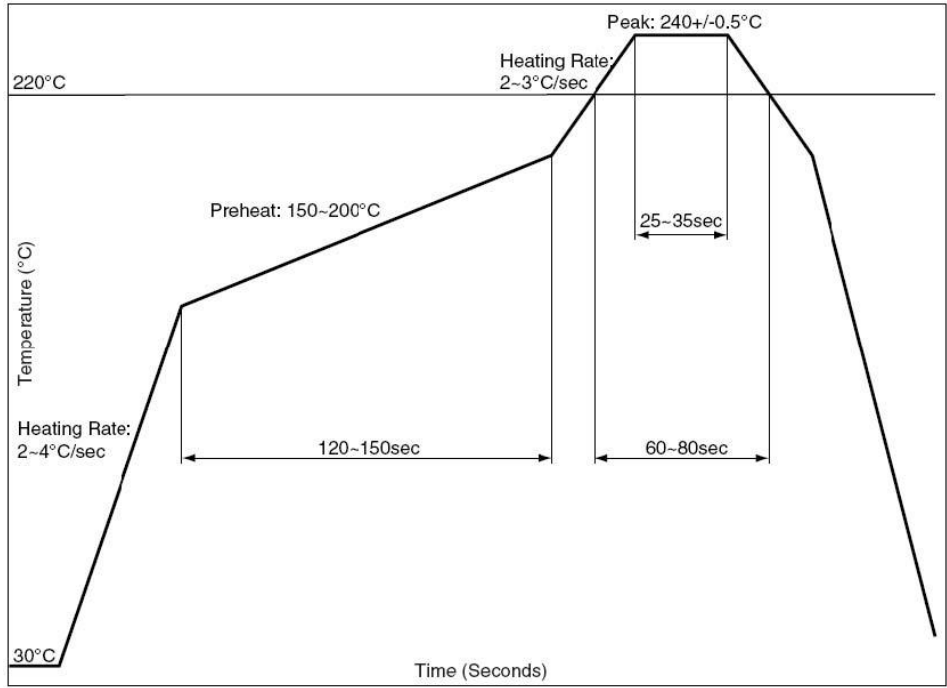

The reflow profile shown above should not be exceeded, since excessive temperatures or transport times during reflow can damage the module. Cooling temperature fall rate: max 3°C / sec